

## Bedding Supports

EH 23220.



### Product Description

The bedding support is used to **support** overdetermined clamping points on components.

The benefits of the bedding support are:

- Support for unstable components, without distortion
- Eliminates tool vibration during machining
- Compact, low construction
- Supports ribs, beads and shackles, for reinforcement of clamped components
- Distortion-free support of raw parts
- Easy handling
- Flat and long design allows clamping with adjustable clamping lever even outside the workpiece.

### Material

#### Handle

- Zinc die-cast

#### Clamp

- Steel, case-hardened, blackened, ground

### Operation

1. By releasing the clamping lever, the support bolt contacts the workpiece with a light spring load.
2. By clamping the clamping lever, the support pin is blocked without displacement.
3. The clamping lever is released after removal of the workpiece. Then push the support pin into the starting position and clamp using the lever.

By screwing grub screws or supports into the support pin's female thread, the support height can be adjusted.

Drawing

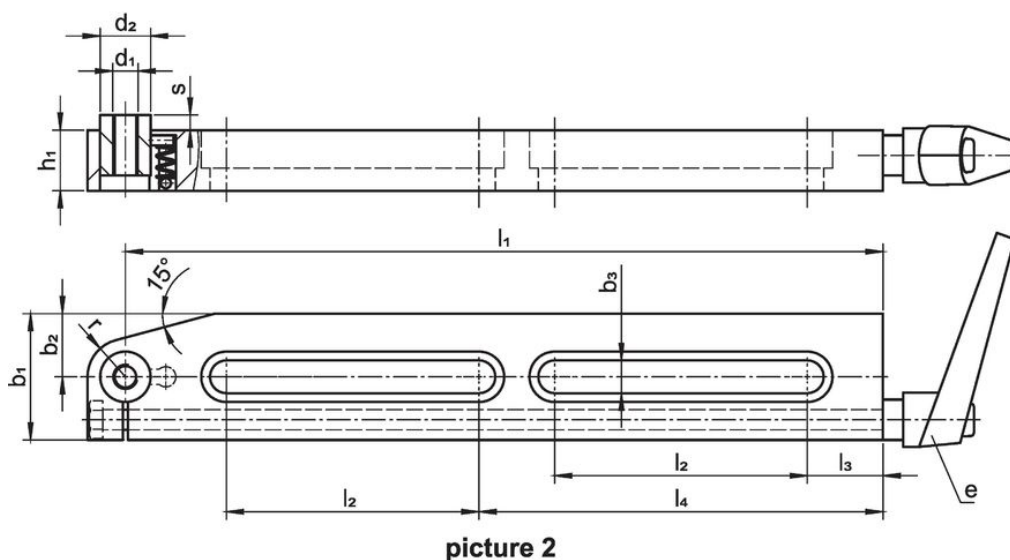
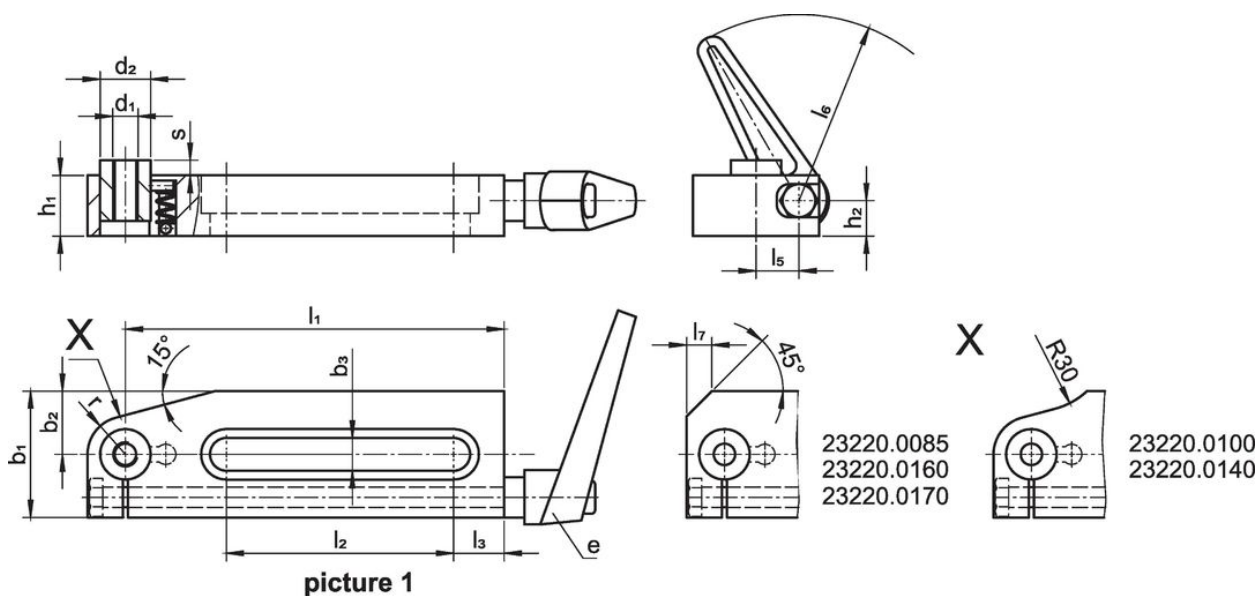

Order information

Dimensions															Stroke s [mm]	Load capacity max. [kN]	e	[g]	Art. No.
b <sub>3</sub>	l <sub>1</sub>	l <sub>2</sub>	l <sub>3</sub>	l <sub>4</sub>	l <sub>5</sub>	l <sub>6</sub>	l <sub>7</sub>	b <sub>1</sub>	b <sub>2</sub>	d <sub>1</sub>	d <sub>2</sub>	h <sub>1</sub>	h <sub>2</sub>	r					
[mm]																			
<b>short version, with one slot – picture 1</b>																			
8.5	75	35	13	-	13	62	5	30	10	M 8	13	19.5	11.5	-	3	0.5	24400.0311	342	<a href="#">23220.0085</a>
11.0	75	28	14	-	17	74	-	50	25	M10	20	24.0	14.0	15	6	2.5	24400.0411	714	<a href="#">23220.0100</a>
11.0	150	90	20	-	17	74	-	50	25	M10	20	24.0	14.0	15	6	2.5	24400.0411	1181	<a href="#">23220.0110</a>
13.0	75	28	14	-	17	74	-	50	25	M10	20	24.0	14.0	15	6	2.5	24400.0411	694	<a href="#">23220.0140</a>
13.0	150	90	20	-	17	74	-	50	25	M10	20	24.0	14.0	15	6	2.5	24400.0411	1379	<a href="#">23220.0150</a>
17.0	75	18	16	-	27	101	11	60	20	M16	26	34.0	13.0	-	11	5.0	24400.0611	1491	<a href="#">23220.0160</a>
17.0	170	100	25	-	27	108	11	60	20	M16	26	34.0	21.5	-	11	5.0	24400.0611	2721	<a href="#">23220.0170</a>
<b>long version, with two slots – picture 2</b>																			
13.0	300	100	30	160	17	74	-	50	25	M10	20	24.0	14.0	15	6	2.5	24400.0411	2448	<a href="#">23220.0300</a>
25.0	387	110	30	200	30	89	-	85	40	M20	32	40.0	25.0	24	11	10.0	24420.0210	7350	<a href="#">23220.0450</a>

Application example

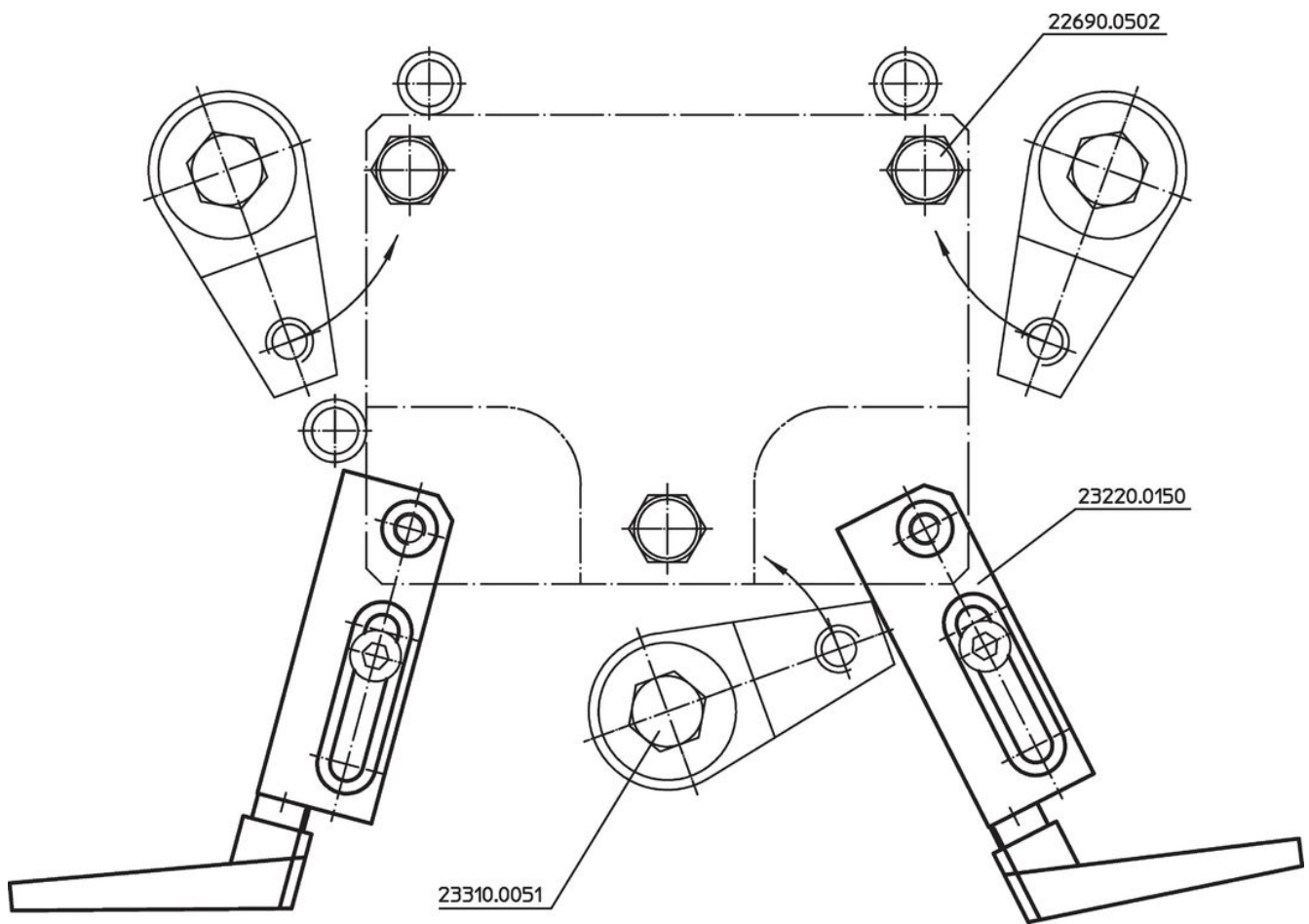
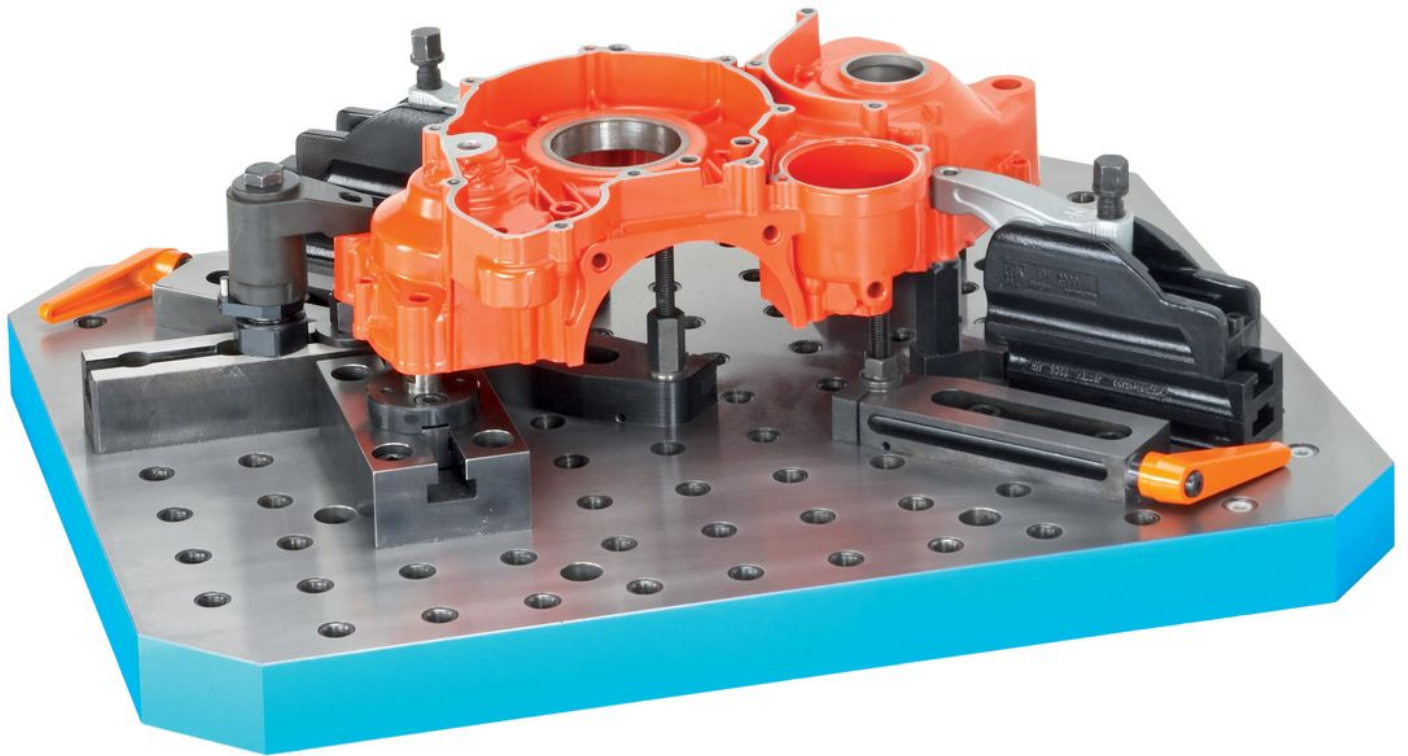

## Compliance

### RoHS compliant

Contains lead - compliant according to exceptions 6a / 6b / 6c.

### Contains SVHC substances >0,1% w/w

Contains lead - SVHC list [REACH] as of 27.06.2024.

### Contains Proposition 65 substances



Lead can cause cancer and reproductive harm from exposure  
<https://www.P65Warnings.ca.gov/>

### Free from Conflict Minerals

This product does not contain any substances designated as "conflict minerals" such as tantalum, tin, gold or tungsten from the Democratic Republic of Congo or adjacent countries.