

## Ball Casters • with sheet steel housing

EH 22750.



### Product Description

Ball casters are module for transport systems, conveyances, to working and packing facilities. For example, parts can be easily moved, turned and controlled. As from  $d_1 = 36$  fitted with an oil drenched felt seal to protect against dirt.

### Material

#### Cap

- Steel, zinc-plated by galvanization
- Stainless steel

#### Housing

- Steel, zinc-plated by galvanization
- Stainless steel

#### Ball

- Ball-bearing steel
- Stainless steel

### More information

#### Further products

- Tolerance Rings

### Drawing

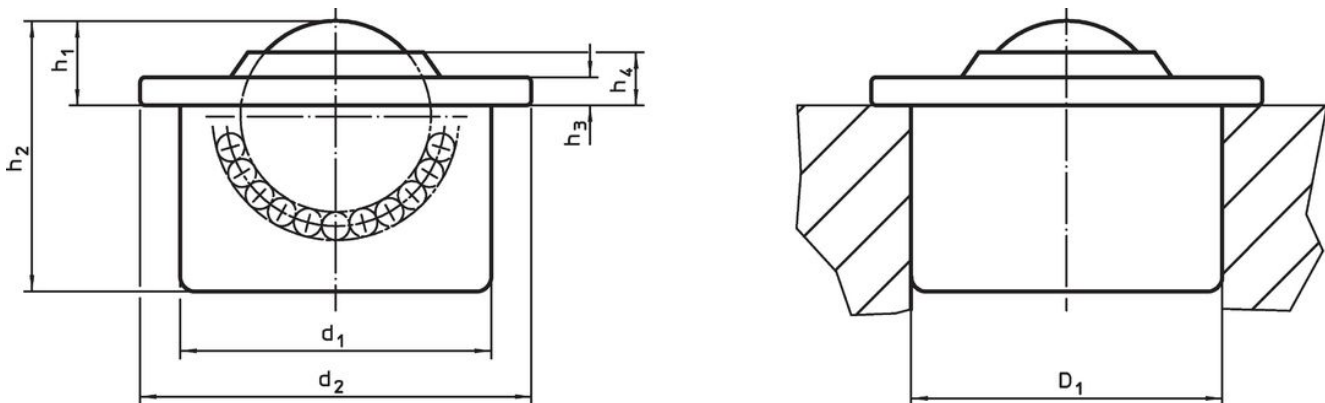

### Order information

$d_1$	Ball diameter	Dimensions					Location hole $D_1^{1)}$	Dynamic carrying figure C	 [g]	Art. No.
		$d_2$	$h_1$	$h_2$	$h_3$	$h_4$				
cap and housing zinc-plated										
12.6 ±0.055	8	17	4.8 ±0.15	11.2	1.8	3.2	12.57 +0.03	100	6.8	22750.0000 <sup>2)</sup>
18.0 ±0.055	12	23	7.4 ±0.15	15.5	2.0	4.3	17.97 +0.03	250	18.0	22750.0002 <sup>2)</sup>
24.0 ±0.065	15	31	9.5 ±0.20	21.5	2.5	6.1	23.95 +0.05	500	40.0	22750.0004 <sup>2)</sup>
36.0 ±0.080	22	45	9.8 ±0.20	29.5	2.9	5.7	35.90 +0.05	1300	131.0	22750.0008
45.0 ±0.080	30	55	13.8 ±0.30	37.5	3.7	7.9	44.85 +0.05	2500	277.0	22750.0012
62.0 ±0.095	45	75	19.0 ±0.40	53.7	4.2	10.3	61.83 +0.07	6000	741.0	22750.0016
all parts zinc-plated, ball from stainless steel										
12.6 ±0.055	8	17	4.8 ±0.15	11.2	1.8	3.2	12.57 +0.03	70	7.0	22750.0020 <sup>2)</sup>
18.0 ±0.055	12	23	7.4 ±0.15	15.5	2.0	4.3	17.97 +0.03	180	18.0	22750.0022 <sup>2)</sup>
24.0 ±0.065	15	31	9.5 ±0.20	21.5	2.5	6.1	23.95 +0.05	370	40.0	22750.0024 <sup>2)</sup>
36.0 ±0.080	22	45	9.8 ±0.20	29.5	2.9	5.7	35.90 +0.05	970	132.0	22750.0028
45.0 ±0.080	30	55	13.8 ±0.30	37.5	3.7	7.9	44.85 +0.05	1900	273.0	22750.0032
62.0 ±0.095	45	75	19.0 ±0.40	53.7	4.2	10.3	61.83 +0.07	4500	739.0	22750.0036

<sup>1)</sup> Reference value for 2 mm sheet steel/ 5 mm aluminium (force fit)

<sup>2)</sup> without felt seal

d <sub>1</sub>	Ball diameter	Dimensions					Location hole D <sub>1</sub> <sup>1)</sup>	Dynamic carrying figure C		Art. No.
		d <sub>2</sub>	h <sub>1</sub>	h <sub>2</sub>	h <sub>3</sub>	h <sub>4</sub>				
[mm]										
all parts from stainless steel										
12.6 ± 0.055	8	17	4.8 ± 0.15	11.2	1.8	3.2	12.57 + 0.03	70	7.0	<a href="#">22750.0040<sup>2)</sup></a>
18.0 ± 0.055	12	23	7.4 ± 0.15	15.5	2.0	4.3	17.97 + 0.03	180	17.0	<a href="#">22750.0042<sup>2)</sup></a>
24.0 ± 0.065	15	31	9.5 ± 0.20	21.5	2.5	6.1	23.95 + 0.05	370	39.0	<a href="#">22750.0044<sup>2)</sup></a>
36.0 ± 0.080	22	45	9.8 ± 0.20	29.5	2.9	5.7	35.90 + 0.05	970	133.0	<a href="#">22750.0048</a>
45.0 ± 0.080	30	55	13.8 ± 0.30	37.5	3.7	7.9	44.85 + 0.05	1900	272.0	<a href="#">22750.0052</a>

<sup>1)</sup> Reference value for 2 mm sheet steel/ 5 mm aluminium (force fit)

<sup>2)</sup> without felt seal

### Application example

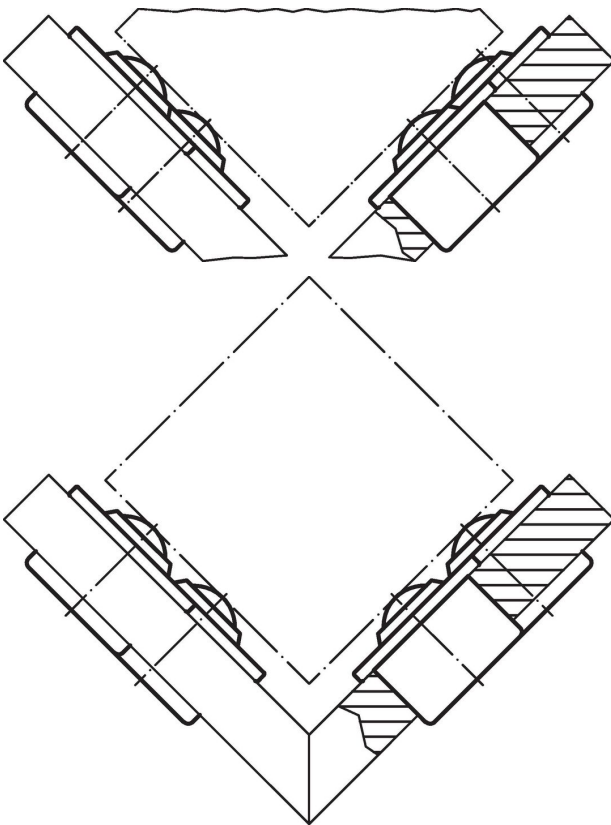

### Compliance

#### RoHS compliant

Compliant according to Directive 2011/65/EU and Directive 2015/863.

#### Does not contain SVHC substances

No SVHC substances with more than 0.1% w/w contained - SVHC list [REACH] as of 23.01.2024.

#### Does not contain Proposition 65 substances

No Proposition 65 substances included.

<https://www.P65Warnings.ca.gov/>

#### Free from Conflict Minerals

This product does not contain any substances designated as "conflict minerals" such as tantalum, tin, gold or tungsten from the Democratic Republic of Congo or adjacent countries.