

Fulcrum Screws

EH 22591.



Product Description

Can be used as screw-in foot or thrust pad.
Compact design for simple levelling by means of the spanner flat at the bushing or preferably by means of an internal hexagon.

Material

Body

- Heat-treated steel, tempered, blackened
- Stainless steel 1.4305

Ball element

- Heat-treated steel, tempered, blackened
- Stainless steel 1.4305

More information

Notes

The fulcrum screws may exclusively be exposed to static loading.

Drawing

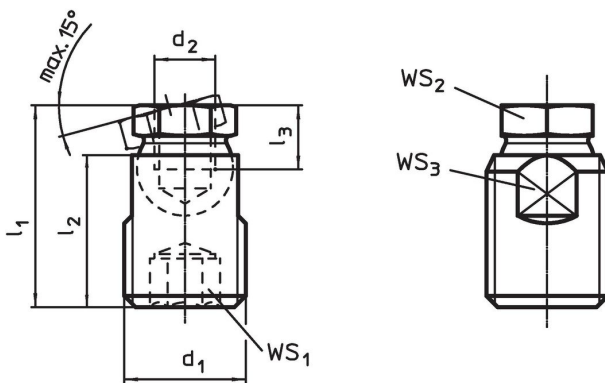

Order information

d ₁	d ₂	Dimensions			WS ₁	WS ₂	WS ₃	Load capacity for static load max.	[g]	Art. No.
		l ₁ ±0.5 [mm]	l ₂	l ₃ min.						
Steel										
M12	M 6	21.2	16	5.0	6	9	10	10	10	22591.0006
M16	M 8	26.5	20	7.0	8	12	14	18	24	22591.0008
M24	M10	39.9	30	9.0	12	19	20	35	87	22591.0010
M24	M12	39.9	30	11.0	12	19	20	35	82	22591.0012
M30 x 2	M16	47.4	36	13.5	12	24	27	45	173	22591.0016
Stainless steel										
M12	M 6	21.2	16	5.0	6	9	10	8	10	22591.0206
M16	M 8	26.5	20	7.0	8	12	14	14	24	22591.0208
M24	M10	39.9	30	9.0	12	19	20	28	87	22591.0210
M24	M12	39.9	30	11.0	12	19	20	28	82	22591.0212
M30 x 2	M16	47.4	36	13.5	12	24	27	36	173	22591.0216

Application example

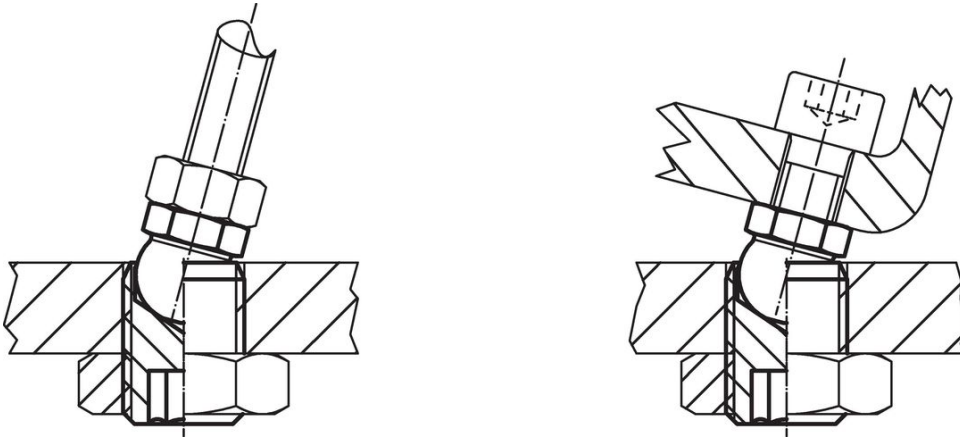

Compliance

For detailed compliance information please select the desired article number.