

Mounting Pads · with fastening holes

EH 22590.



Product Description

Mounting pads can be used as foot or thrust pad. Not parallel bearing surfaces up to 15° degrees can be compensated.
Including two fastening holes in pad.

Material

Ball element

- Stainless steel 1.4305

Ball element with bolt

- Stainless steel 1.4305

Lock nut

- Stainless Steel A2, ISO 4032
- Stainless Steel A2, DIN 934

Pad

- Stainless steel 1.4305

More information

Notes

For the versions $d_1 = M10$ and $M12$ the lock nut conforms to DIN 934.

Drawing

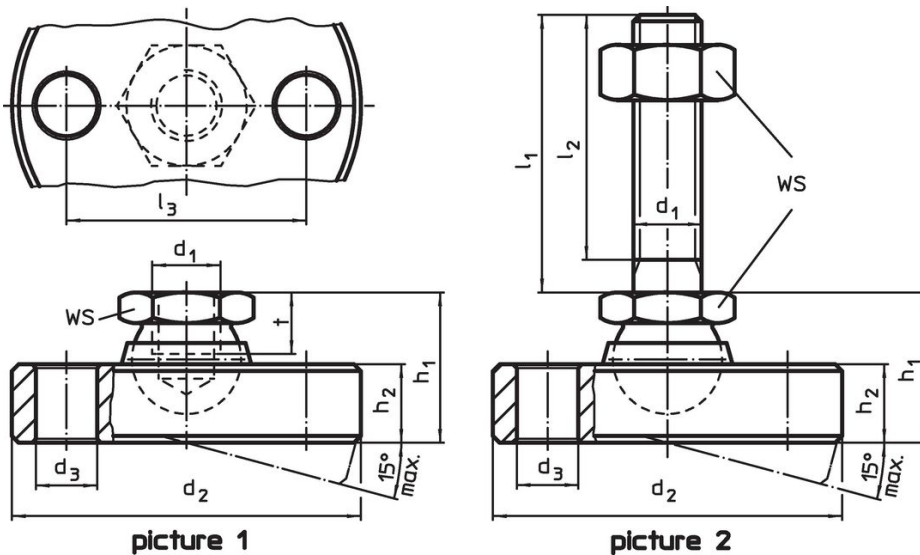

Order information

d_1	l_1	d_2 -0.5	d_3	Dimensions					WS	Load capacity for static load max.	[g]	Art. No.
				l_2	l_3	h_1 ~	h_2	t				
pad and ball element from stainless steel – picture 1												
M 6	–	45	6.6	–	32	14	6.5	5.0	10	8	79	22590.0706
M 8	–	50	6.6	–	38	18	8.5	7.0	13	14	131	22590.0708
M10	–	60	9.0	–	44	22	11.5	9.0	17	16	251	22590.0710
M12	–	65	9.0	–	48	26	12.5	11.0	19	28	324	22590.0712
M16	–	70	9.0	–	54	32	13.5	13.5	24	36	492	22590.0716
M20	–	80	9.0	–	64	42	16.5	17.0	30	44	784	22590.0720
M24	–	100	11.0	–	78	45	20.5	19.0	36	52	1392	22590.0724
pad and ball element with bolt from stainless steel – picture 2												
M 6	60	45	6.6	57.0	32	14	6.5	–	10	8	93	22590.0810
M 8	80	50	6.6	76.0	38	18	8.5	–	13	14	163	22590.0822
M10	100	60	9.0	95.5	44	22	11.5	–	17	16	316	22590.0838
M10	150	60	9.0	145.5	44	22	11.5	–	17	16	340	22590.0842
M12	100	65	9.0	94.5	48	26	12.5	–	19	28	481	22590.0852
M12	150	65	9.0	144.5	48	26	12.5	–	19	28	510	22590.0856
M16	100	70	9.0	94.0	54	32	13.5	–	24	36	617	22590.0868

d ₁	l ₁	d ₂ -0.5	Dimensions						WS [mm]	Load capacity for static load max. [kN]	 [g]	Art. No.
			d ₃	l ₂	l ₃	h ₁ ~	h ₂	t				
[mm]												
M16	200	70	9.0	194.0	54	32	13.5	–	24	36	905	22590.0872
M20	100	80	9.0	92.5	64	42	16.5	–	30	44	1125	22590.0882
M20	200	80	9.0	192.5	64	42	16.5	–	30	44	1408	22590.0888
M24	100	100	11.0	91.0	78	45	20.5	–	36	52	1906	22590.0895
M24	200	100	11.0	191.0	78	45	20.5	–	36	52	2000	22590.0898

Application example

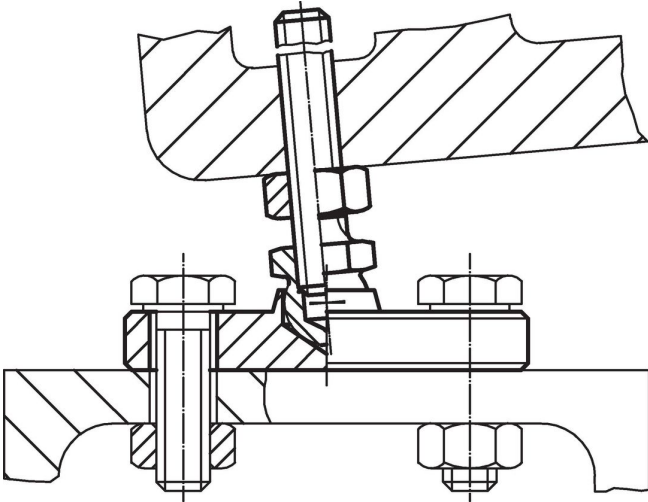

Compliance

RoHS compliant

Compliant according to Directive 2011/65/EU and Directive 2015/863.

Does not contain SVHC substances

No SVHC substances with more than 0.1% w/w contained - SVHC list [REACH] as of 23.01.2024.

Does not contain Proposition 65 substances

No Proposition 65 substances included.

<https://www.P65Warnings.ca.gov/>

Free from Conflict Minerals

This product does not contain any substances designated as "conflict minerals" such as tantalum, tin, gold or tungsten from the Democratic Republic of Congo or adjacent countries.