

## Lateral Plungers • with thread, with seal

EH 22150.



### Product Description

To be used for positioning and applying pressure, e.g. during painting and sandblasting. Sealed against chips and dirt.

### Material

#### Seal

- CR

#### Body

- Steel, zinc-plated by galvanization

#### Spring

- Stainless steel
- Steel, blackened
- Steel, zinc-plated by galvanization

#### Pin

- Steel, case-hardened, zinc-plated by galvanization
- Thermoplastic POM, white

### Assembly

Lateral plungers are installed by screwing in by means of a mounting tool.

Formula for calculating the center distance for the mounting hole:

$$l_0 = z/2 + w + x,$$

$l_0$  = center distance,

$y$  = workpiece height,

$w$  = workpiece length,

$x$  = coordinate dimension,

$s$  = stroke,

$z$  = stop diameter

Calculation dimension  $x$ :

$y$  greater than or equal to  $l_2 - d_2/2$ ,

then  $x = d_2/2 - s$

(value  $x$  for this case see table)

or

$y$  smaller than  $l_2 - d_2/2$ ,

then  $x = d_2/2 - s - [(l_2 - d_2/2 - y) * 0,123]$

### Characteristic

Version light spring load = spring from stainless steel

Version standard spring load = spring from steel, blackened

Version heavy spring load = spring from steel, zinc-plated by galvanization

### Drawing

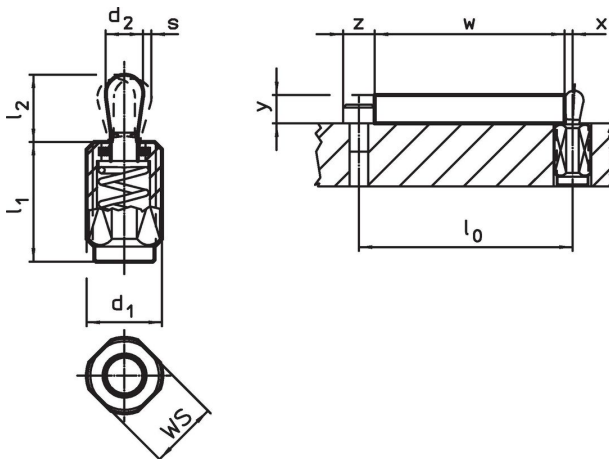



Order information

d <sub>1</sub> [mm]	Dimensions		d <sub>2</sub> [mm]	l <sub>2</sub> [mm]	Stroke s [mm]	WS [mm]	x <sup>1)</sup> [mm]	max. [°C]	 [g]	Art. No.
	l <sub>1</sub> -2 [mm]	Spring load F max. <sup>2)</sup> ~ [N]								
<b>Pin: Steel/Light spring load</b>										
M12	11.5	20	5	6	0.8	10	1.7	110	3.8	22150.0410
M12	19.0	20	5	6	0.8	10	1.7	110	5.6	22150.0414
M12	26.5	20	5	6	0.8	10	1.7	110	7.5	22150.0418
M12	11.5	40	6	10	1.0	10	2.0	110	4.7	22150.0430
M12	19.0	40	6	10	1.0	10	2.0	110	6.5	22150.0434
M12	26.5	40	6	10	1.0	10	2.0	110	8.3	22150.0438
M18 x 1,5	18.0	100	10	16	1.6	16	3.4	110	20.0	22150.0450
M18 x 1,5	31.5	100	10	16	1.6	16	3.4	110	28.0	22150.0454
M18 x 1,5	45.0	100	10	16	1.6	16	3.4	110	36.0	22150.0458
<b>Pin: Steel/Standard spring load</b>										
M12	11.5	50	5	6	0.8	10	1.7	110	4.1	22150.0411
M12	19.0	50	5	6	0.8	10	1.7	110	6.3	22150.0415
M12	26.5	50	5	6	0.8	10	1.7	110	8.1	22150.0419
M12	11.5	75	6	10	1.0	10	2.0	110	4.8	22150.0431
M12	19.0	75	6	10	1.0	10	2.0	110	6.9	22150.0435
M12	26.5	75	6	10	1.0	10	2.0	110	8.9	22150.0439
M18 x 1,5	18.0	150	10	16	1.6	16	3.4	110	20.0	22150.0451
M18 x 1,5	31.5	150	10	16	1.6	16	3.4	110	29.0	22150.0455
M18 x 1,5	45.0	150	10	16	1.6	16	3.4	110	40.0	22150.0459
<b>Pin: Steel/Heavy spring load</b>										
M12	11.5	100	5	6	0.8	10	1.7	110	4.2	22150.0412
M12	19.0	100	5	6	0.8	10	1.7	110	6.6	22150.0416
M12	26.5	100	5	6	0.8	10	1.7	110	8.7	22150.0420
M12	11.5	100	6	10	1.0	10	2.0	110	5.4	22150.0432
M12	19.0	100	6	10	1.0	10	2.0	110	7.6	22150.0436
M12	26.5	100	6	10	1.0	10	2.0	110	10.0	22150.0440
M18 x 1,5	18.0	200	10	16	1.6	16	3.4	110	20.0	22150.0452
M18 x 1,5	31.5	200	10	16	1.6	16	3.4	110	29.0	22150.0456
M18 x 1,5	45.0	200	10	16	1.6	16	3.4	110	38.0	22150.0460
<b>Pin: Thermoplastic/Light spring load</b>										
M12	11.5	20	5	6	0.8	10	1.7	80	2.6	22150.0470
M12	19.0	20	5	6	0.8	10	1.7	80	4.4	22150.0475
M12	26.5	20	5	6	0.8	10	1.7	80	6.1	22150.0483
M12	11.5	40	6	10	1.0	10	2.0	80	2.7	22150.0473
M12	19.0	40	6	10	1.0	10	2.0	80	4.5	22150.0480
M12	26.5	40	6	10	1.0	10	2.0	80	6.2	22150.0485
M18 x 1,5	18.0	100	10	16	1.6	16	3.4	80	12.0	22150.0490
M18 x 1,5	31.5	100	10	16	1.6	16	3.4	80	21.0	22150.0493
M18 x 1,5	45.0	100	10	16	1.6	16	3.4	80	30.0	22150.0495

<sup>1)</sup> If the workpiece height (y) is less than l<sub>2</sub>-d<sub>2</sub>/2, the coordinate dimension (x) must be calculated.

<sup>2)</sup> statistical average value

Accessories

	Dimensions	 [g]	Art. No.
	d <sub>1</sub> [mm]		
<b>assembly tool</b>			
	M12	76	22150.0820
	M18 x 1,5	137	22150.0822

Application example

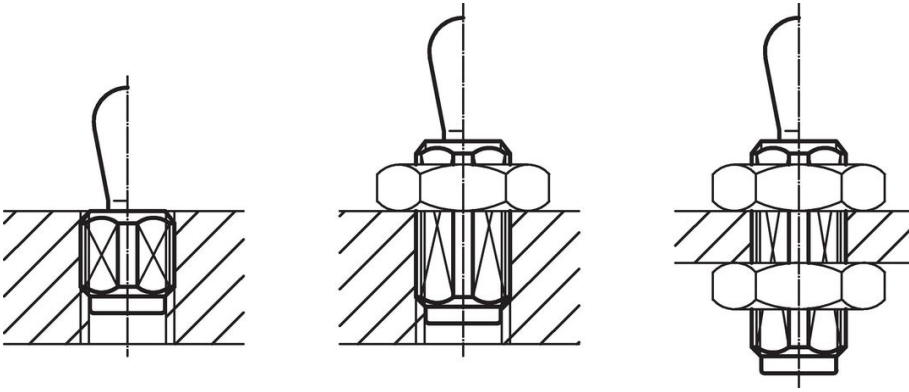

Compliance

For detailed compliance information please select the desired article number.