

Index Plungers · with pull-ring EH 22120.



Product Description

Index plungers are used for indexing bores.

Material

Body

- Steel, blackened
- Stainless steel 1.4305

Locking pin

- Stainless steel 1.4305, nickel-plated

Pull-ring

- Stainless steel 1.4310

Assembly

Lock nuts have to be purchased separately.

Operation

When using the model with locking mechanism, you turn the pull-ring by 90° after retracting the locking pin and secure the ring using the notched catch (if the locking pin should not overhang).

More information

Further products

- Mounting Blocks, for index bolts and index plungers, die-cast
- Locating Bushings, for index bolts and index plungers
- Distance Collars, for index plungers
- Mounting Blocks, for index bolts and index plungers

Drawing

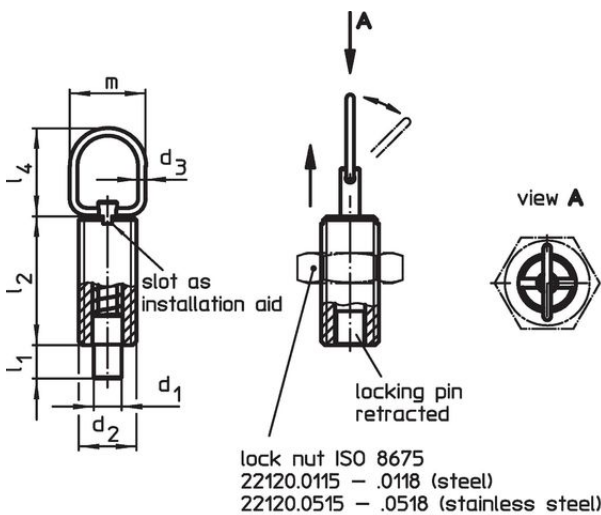

picture 1

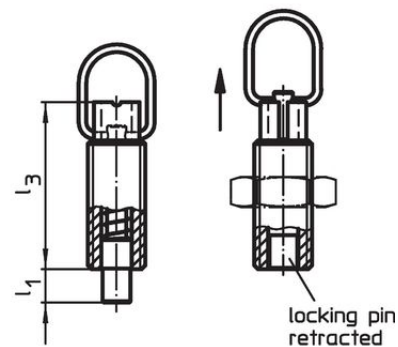

with locking

picture 2

Order information





Dimensions								Stroke s [mm]	Spring load ¹⁾		max. [°C]	[g]	Art. No.
d ₁ -0.05 -0.1	d ₂	d ₃	l ₁ min. [mm]	l ₂	l ₃	l ₄	m		F ₁ ~ [N]	F ₂ ~ [N]			
without locking – picture 1, Steel													
5	M10	1.5	5	22	28	23	18	5	5	15	250	11	22120.1310
5	M10 x 1	1.5	5	22	28	23	18	5	5	15	250	12	22120.1312
6	M12	2.0	6	24	31	25	22	6	6	21	250	18	22120.1314
6	M12 x 1,5	2.0	6	24	31	25	22	6	6	21	250	18	22120.1316

¹⁾ statistical average value

d ₁ -0.05 -0.1	d ₂	Dimensions						Stroke s [mm]	Spring load ¹⁾		max. [°C]	 [g]	Art. No.
		d ₃	l ₁ min. [mm]	l ₂	l ₃	l ₄	m		F ₁ ~ [N]	F ₂ ~ [N]			
8	M16	2.0	9	34	44	25	22	9	7	27	250	43	22120.1318
8	M16 x 1,5	2.0	9	34	44	25	22	9	7	27	250	45	22120.1320
10	M16	2.0	9	34	44	25	22	9	7	27	250	45	22120.1322
10	M16 x 1,5	2.0	9	34	44	25	22	9	7	27	250	47	22120.1324
without locking – picture 1, Stainless steel													
5	M10	1.5	5	22	28	23	18	5	5	15	250	11	22120.1410
5	M10 x 1	1.5	5	22	28	23	18	5	5	15	250	12	22120.1412
6	M12	2.0	6	24	31	25	22	6	6	21	250	18	22120.1414
6	M12 x 1,5	2.0	6	24	31	25	22	6	6	21	250	18	22120.1416
8	M16	2.0	9	34	44	25	22	9	7	27	250	43	22120.1418
8	M16 x 1,5	2.0	9	34	44	25	22	9	7	27	250	45	22120.1420
10	M16	2.0	9	34	44	25	22	9	7	27	250	45	22120.1422
10	M16 x 1,5	2.0	9	34	44	25	22	9	7	27	250	47	22120.1424
with locking – picture 2, Steel													
5	M10	1.5	5	22	28	23	18	5	5	15	250	12	22120.1340
5	M10 x 1	1.5	5	22	28	23	18	5	5	15	250	13	22120.1342
6	M12	2.0	6	24	31	25	22	6	6	21	250	19	22120.1344
6	M12 x 1,5	2.0	6	24	31	25	22	6	6	21	250	20	22120.1346
8	M16	2.0	9	34	44	25	22	9	7	27	250	48	22120.1348
8	M16 x 1,5	2.0	9	34	44	25	22	9	7	27	250	51	22120.1350
10	M16	2.0	9	34	44	25	22	9	7	27	250	50	22120.1352
10	M16 x 1,5	2.0	9	34	44	25	22	9	7	27	250	53	22120.1354
with locking – picture 2, Stainless steel													
5	M10	1.5	5	22	28	23	18	5	5	15	250	12	22120.1440
5	M10 x 1	1.5	5	22	28	23	18	5	5	15	250	13	22120.1442
6	M12	2.0	6	24	31	25	22	6	6	21	250	19	22120.1444
6	M12 x 1,5	2.0	6	24	31	25	22	6	6	21	250	20	22120.1446
8	M16	2.0	9	34	44	25	22	9	7	27	250	48	22120.1448
8	M16 x 1,5	2.0	9	34	44	25	22	9	7	27	250	51	22120.1450
10	M16	2.0	9	34	44	25	22	9	7	27	250	50	22120.1452
10	M16 x 1,5	2.0	9	34	44	25	22	9	7	27	250	53	22120.1454

¹⁾ statistical average value

Accessories

	Dimensions d ₂ [mm]	Wrench size [mm]	 [g]	Art. No.
Lock nuts ISO 4035, Steel				
	M10	16	5.3	22120.0706
	M12	18	7.6	22120.0708
	M16	24	18.0	22120.0710
Lock nuts ISO 4035, Stainless steel				
	M10	16	5.3	22120.0716
	M12	18	7.6	22120.0718
	M16	24	18.0	22120.0720
Lock nuts ISO 8675 (DIN 439), Steel				
	M10 x 1	16	5.2	22120.0115
	M12 x 1,5	18	7.5	22120.0116
	M16 x 1,5	24	15.0	22120.0118
Lock nuts ISO 8675 (DIN 439), Stainless steel				
	M10 x 1	16	5.2	22120.0515
	M12 x 1,5	18	7.5	22120.0516
	M16 x 1,5	24	15.0	22120.0518

Application example

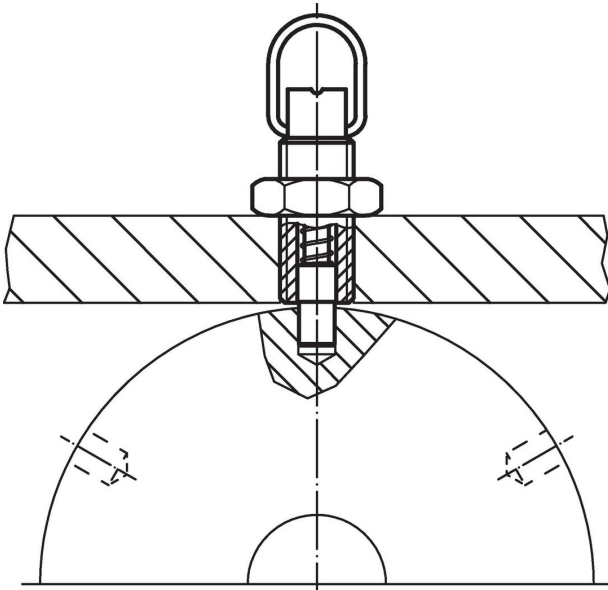

Compliance

For detailed compliance information please select the desired article number.