

## Spring Plungers · with moveable ball and internal hexagon EH 22031.



### Product Description

Spring plungers can be used for locating or for applying pressure, as a detent or for ejection. The running of the ball minimises wear on the counterpart, this also results in a positive locking behaviour depending on the counterpart. Another advantage of the plastic ball is the electric insulation.

### Material

#### Body

- Free cutting steel, blackened
- Stainless steel 1.4305

#### Bearing

- plastic

#### Ball

- Ball-bearing steel, hardened
- Stainless steel, hardened

#### Spring

- Stainless steel

### Characteristic

Standard spring load: no marking  
Heavy spring load: marked with two lines



Standard spring load



Heavy spring load

### More information

### Notes

Special types on request.  
Spring plungers are specially tested for spring range and forces.

### References

Thread lock on request, please refer to appendix - Technical Data -  
Calculation of indexing resistance, please refer to appendix - Technical Data -

### Drawing

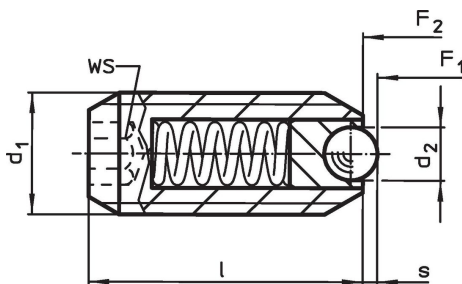

### Order information

Dimensions			WS	Stroke s	Spring load <sup>1)</sup>		min.	max.	[g]	Art. No.
d <sub>1</sub>	d <sub>2</sub>	l			F <sub>1</sub>	F <sub>2</sub>				
[mm]			[mm]	[mm]	~	~	[°C]			
<b>free cutting steel, standard spring load</b>										
M 5	2.0	14	2.5	0.50	4.8	6.8	-30	90	1.0	22031.0005
M 6	2.5	15	3.0	0.70	6.3	10.0	-30	90	1.6	22031.0006
M 8	3.5	18	4.0	0.95	16.0	24.0	-30	90	3.7	22031.0008
M10	4.5	23	5.0	1.40	18.8	31.7	-30	90	7.4	22031.0010
M12	6.5	26	6.0	2.50	24.0	49.0	-30	90	11.0	22031.0012
M16	8.5	33	8.0	3.10	38.0	68.0	-30	90	30.0	22031.0016
<b>free cutting steel, heavy spring load</b>										
M 5	2.0	14	2.5	0.50	10.0	14.0	-30	90	1.1	22031.0045
M 6	2.5	15	3.0	0.70	11.0	16.0	-30	90	1.6	22031.0046
M 8	3.5	18	4.0	0.95	23.0	40.0	-30	90	3.7	22031.0048
M10	4.5	23	5.0	1.40	28.0	54.3	-30	90	7.4	22031.0050
M12	6.5	26	6.0	2.50	36.5	77.3	-30	90	12.0	22031.0052
M16	8.5	33	8.0	3.10	50.0	88.7	-30	90	30.0	22031.0056

<sup>1)</sup> statistical average value

Dimensions			WS [mm]	Stroke s [mm]	Spring load <sup>1)</sup>		min.   max.		[g]	Art. No.
d <sub>1</sub>	d <sub>2</sub>	l			F <sub>1</sub> ~ [N]	F <sub>2</sub> ~ [N]	[°C]			
[mm]										
<b>stainless steel, standard spring load</b>										
M 5	2.0	14	2.5	0.50	4.8	6.8	-30	90	1.1	<a href="#">22031.0205</a>
M 6	2.5	15	3.0	0.70	6.3	10.0	-30	90	1.6	<a href="#">22031.0206</a>
M 8	3.5	18	4.0	0.95	16.0	24.0	-30	90	3.7	<a href="#">22031.0208</a>
M10	4.5	23	5.0	1.40	18.8	31.7	-30	90	7.5	<a href="#">22031.0210</a>
M12	6.5	26	6.0	2.50	24.0	49.0	-30	90	11.0	<a href="#">22031.0212</a>
M16	8.5	33	8.0	3.10	38.0	68.0	-30	90	30.0	<a href="#">22031.0216</a>
<b>stainless steel, heavy spring load</b>										
M 5	2.0	14	2.5	0.50	10.0	14.0	-30	90	1.1	<a href="#">22031.0245</a>
M 6	2.5	15	3.0	0.70	11.0	16.0	-30	90	1.6	<a href="#">22031.0246</a>
M 8	3.5	18	4.0	0.95	23.0	40.0	-30	90	3.7	<a href="#">22031.0248</a>
M10	4.5	23	5.0	1.40	28.0	54.3	-30	90	7.4	<a href="#">22031.0250</a>
M12	6.5	26	6.0	2.50	36.5	77.3	-30	90	11.0	<a href="#">22031.0252</a>
M16	8.5	33	8.0	3.10	50.0	88.7	-30	90	31.0	<a href="#">22031.0256</a>

<sup>1)</sup> statistical average value

### Application example

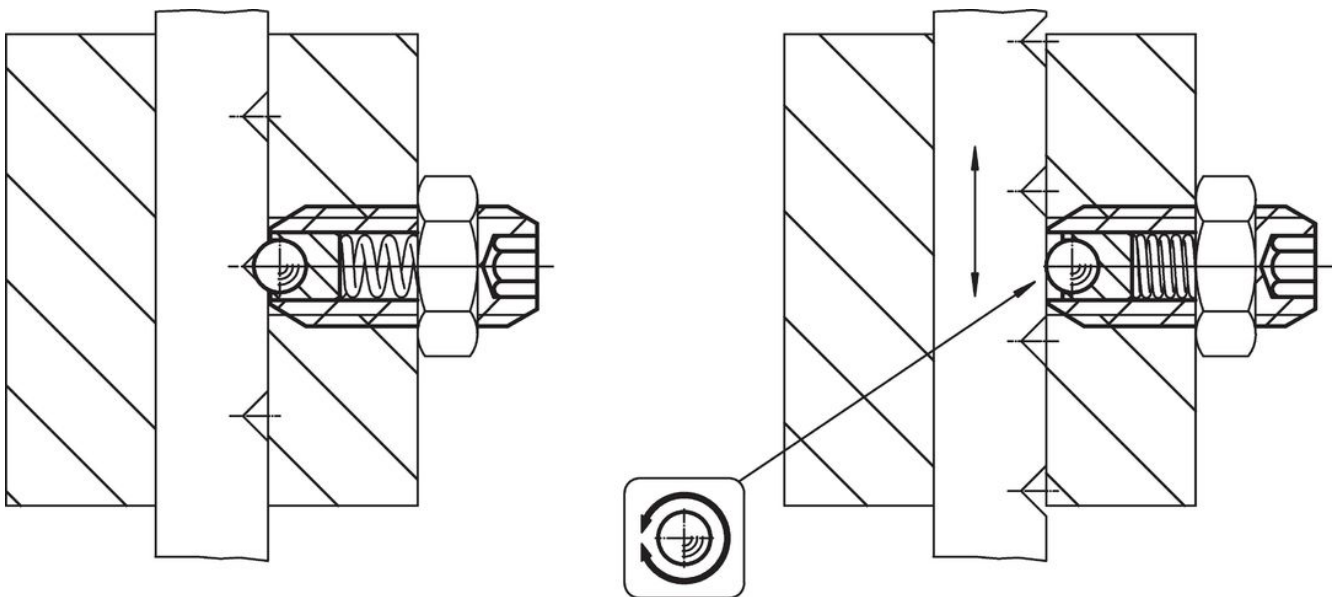

### Compliance

For detailed compliance information please select the desired article number.