

## Spring Push Plungers · with mounting flange, horizontal

22170.1010

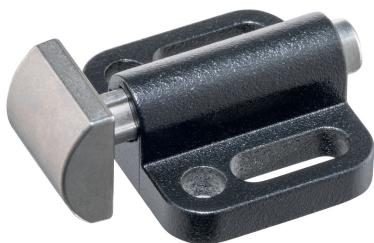

### Product Description

The spring push plungers are used for simple and secure positioning of workpieces or components on stops and support points.

The spring push plunger is designed with a thrust pad that can be rotated 4 x 90° depending on the application.

Below  $h_2$ , a pull-down effect is created when the thrust pad is installed in the appropriate position.

### Material

#### Body

- Zinc die-cast, plastic coated, black, similar to RAL 9005, matt structure

#### Thrust Pad

- Stainless steel 1.4542

#### Screw

- Stainless steel A2

#### Spring

- Stainless steel 1.4310

### Assembly

Assembly by means of washers ISO 7092.

### Drawing

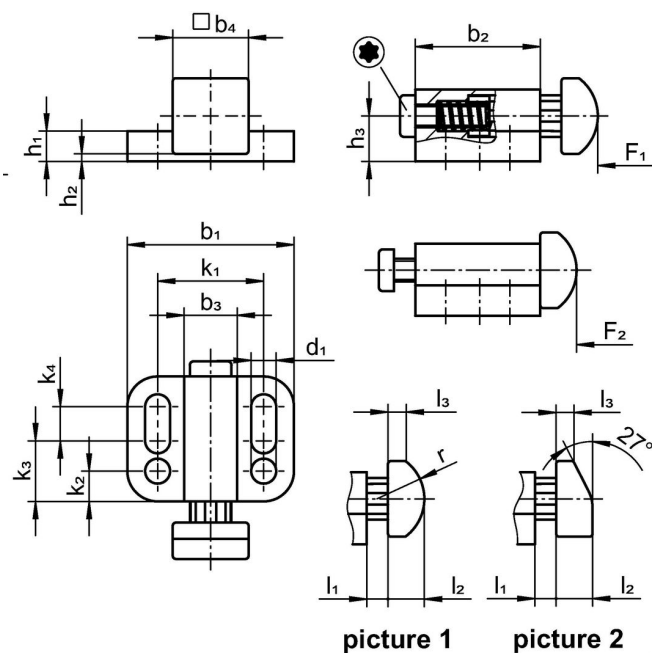

picture 1

picture 2

### Order information

Dimensions																Stroke	Spring load <sup>1)</sup>	Art. No.			
b <sub>1</sub>	d <sub>1</sub>	b <sub>2</sub>	b <sub>3</sub>	b <sub>4</sub>	h <sub>1</sub>	h <sub>2</sub> +0.5	h <sub>3</sub>	k <sub>1</sub>	k <sub>2</sub>	k <sub>3</sub>	k <sub>4</sub>	l <sub>1</sub>	l <sub>2</sub>	l <sub>3</sub>	r	s			F <sub>1</sub>	F <sub>2</sub>	[g]
[mm]																[mm]	[N]				
plunger rounded, heavy spring load – picture 1, Stainless steel																					
32	5.4	27.5	10	16	5	1	9	21	5.5	12	10	5	7	3.1	10	5	20	19	45	40	22170.1010

<sup>1)</sup> statistical average value

## Compliance

### RoHS compliant

Compliant according to Directive 2011/65/EU and Directive 2015/863.

### Does not contain SVHC substances

No SVHC substances with more than 0.1% w/w contained - SVHC list [REACH] as of 27.06.2024.

### Does not contain Proposition 65 substances

No Proposition 65 substances included.

<https://www.P65Warnings.ca.gov/>

### Free from Conflict Minerals

This product does not contain any substances designated as "conflict minerals" such as tantalum, tin, gold or tungsten from the Democratic Republic of Congo or adjacent countries.