

## Lateral Plungers · with plastic spring and pin

22150.0206



### Product Description

To be used for positioning and applying pressure, e.g. during painting and sandblasting.

#### Material

##### Spring

- plastic

##### Pin

- Steel, case-hardened, blackened

#### Assembly

It is recommended to moisten the body.

Installation by pressing in.

Formula for calculating the center distance for the mounting hole:

$$l_0 = z/2 + w + x,$$

$l_0$  = center distance,

$y$  = workpiece height,

$w$  = workpiece length,

$x$  = coordinate dimension,

$s$  = stroke,

$z$  = stop diameter

Calculation dimension  $x$ :

$y$  greater than or equal to  $l_2 - d_2/2$ ,

then  $x = d_2/2 - s$

(value  $x$  for this case see table)

or

$y$  smaller than  $l_2 - d_2/2$ ,

then  $x = d_2/2 - s - [(l_2 - d_2/2 - y) * 0,123]$

#### Characteristic

Version heavy spring load = green spring

#### More information

#### Notes

This is a discontinued article.

### Drawing

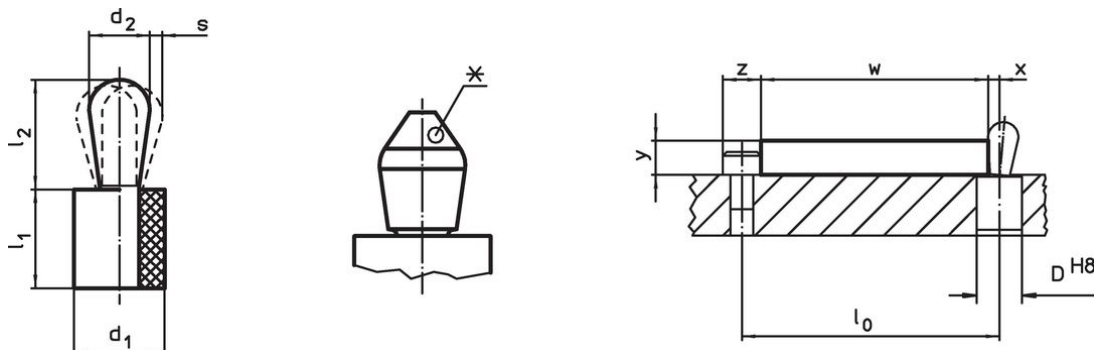

\*some sizes (see chart) have a deviating pin shape



### Order information

Dimensions		Spring load F max. <sup>1)</sup> ~ [N]	Dimensions		Stroke s [mm]	Location hole D H8 [mm]	$x^{2)}$ [mm]	max. [°C]	[g]	Art. No.
$d_1$	$d_2$		$l_1$ -1	$l_2$ $\pm 0.5$						
[mm]			[mm]							
10	5	90	9	7.3	0.4	9.9	1.6	100	2.1	22150.0206

<sup>1)</sup> statistical average value

<sup>2)</sup> If the workpiece height ( $y$ ) is less than  $l_2 - d_2/2$ , the coordinate dimension ( $x$ ) must be calculated.

Accessories

	Dimensions d <sub>1</sub> [mm]	 [g]	Art. No.
<b>assembly tool</b>			
	10	46	22150.0842

Compliance

**RoHS compliant**

Compliant according to Directive 2011/65/EU and Directive 2015/863.

**Does not contain SVHC substances**

No SVHC substances with more than 0.1% w/w contained - SVHC list [REACH] as of 27.06.2024.

**Does not contain Proposition 65 substances**

No Proposition 65 substances included.

<https://www.P65Warnings.ca.gov/>

**Free from Conflict Minerals**

This product does not contain any substances designated as "conflict minerals" such as tantalum, tin, gold or tungsten from the Democratic Republic of Congo or adjacent countries.