

## Clamping Cubes • semi-finished

1908.410



### Product Description

#### Material

- Grey cast iron GG

#### More information

#### Notes

Special plates on request.

#### Further products

- Threaded Lifting Pins, self-locking

### Drawing

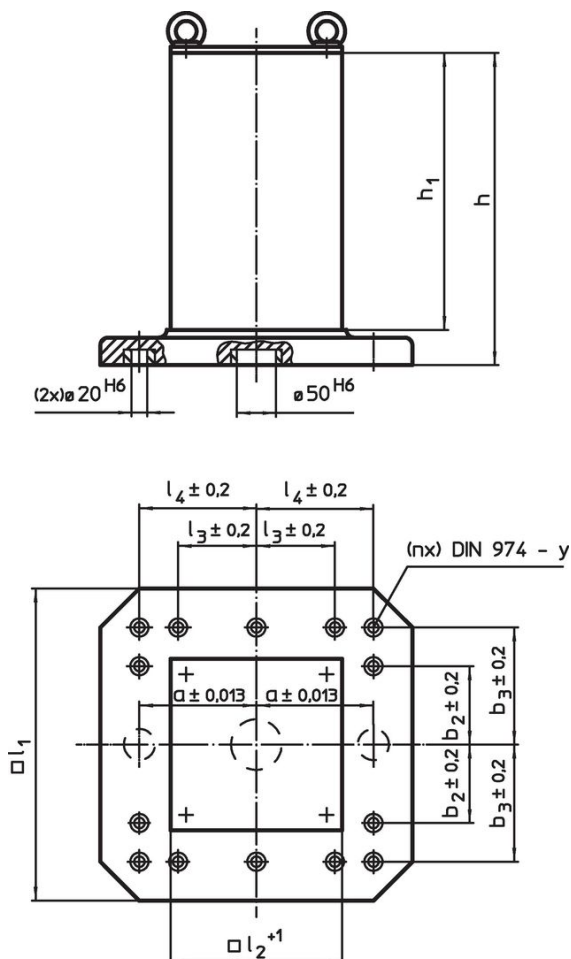

### Order information

Dimensions							y	For screws	Number of fastening holes n	 [kg]	Art. No.
$l_1$	$l_2$ +1	$h_1$	h	a $\pm 0.013$	$b_3$ $\pm 0.2$	$l_4$ $\pm 0.2$					
500	331	510	565	200	200	200	12	M12	6	209	1908.410

## Application example

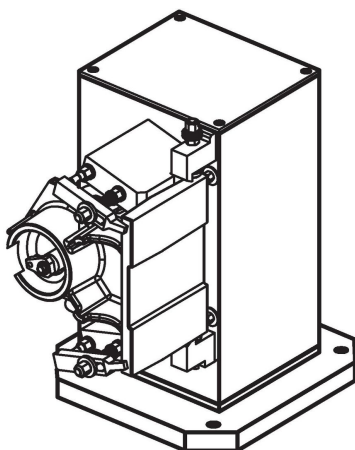

## Compliance

### RoHS compliant

Contains lead - compliant according to exceptions 6a / 6b / 6c.

### Contains SVHC substances >0,1% w/w

Contains lead - SVHC list [REACH] as of 23.01.2024.

### Contains Proposition 65 substances



Lead can cause cancer and reproductive harm from exposure  
<https://www.P65Warnings.ca.gov/>

### Free from Conflict Minerals

This product does not contain any substances designated as "conflict minerals" such as tantalum, tin, gold or tungsten from the Democratic Republic of Congo or adjacent countries.