

Multi-Vices · MS 125

1700.200



Product Description

Scope of application:

- Can be applied horizontally and vertically - therefore suitable for vertical and horizontal CNC milling machines
- Conventional clamping, gripper clamping or pull-down clamping are all possible
- MS 125-S - ideal for use on five-axis machining centres
- Clamping of unmachined parts, saw-cut or flame-cut material by penetration of hardened, replaceable gripper elements into the workpiece
- With the support jaws, unmachined parts in highly varied materials, or with complex geometries, can be clamped securely and economically

Product features:

- High versatility - the modular clamping system combines practically all the possibilities of our tried-and-tested models
- High-pressure spindle with power intensification - clamping force does not slacken
- Enlarged clamping span for secure clamping of unmachined parts
- Lost clamping margin 8 mm with pull-down clamping, 3 mm with gripper clamping
- Clamping with torque wrench (max. 30 Nm) - this makes it possible to work above the table with an unfavourable clamping arrangement on the tool

Scope of supply:

- 1 high-pressure vice without jaws
- 1 set of clamping claws
- 3 socket screw wrenches
- 1 hexagonal insert for torque wrench 3/8"

Please order the clamping jaws separately.

Material

- Ductile cast iron (GGG 60)

More information**Further products**

- Multi-Vices, MS 125eco
- Workpiece Stops, swivelling
- Workpiece Stops
- Torque Wrenches
- Clamping Claws
- Aligning and Fixing Sets
- Step Jaws
- Base Jaws, hard
- Pivot Jaws, movable
- Master Jaw Adapters
- Jaws, Soft
- Snap-On Parallels, click
- Jaws, ribbed
- Base Jaws, Soft
- Prismatic Jaws
- Step Jaws
- Mounting Screws, for jaws
- Support Jaws, orienting
- Support Jaws
- Step Jaws, for gripper studs
- Universal Gripsets
- Gripper Studs
- Locating Pins, for gripper studs
- Supporting Plates
- Gripper Studs, pointed
- Gripper Studs, low
- Gripper Studs, four-point
- Gripper Studs, smooth
- Gripper Studs, round
- Pull-Down Sets, low
- Pull-Down Sets, high
- Wedge Adapters, low
- Wedge Adapters, high
- Wedge Elements, four-point
- Wedge Elements, microgripper
- Wedge Elements, coated
- Wedge Elements, round
- Seating Pins
- Jaws for Five-Sided Machining
- Jaw Sets for Five-Sided Machining
- Gripper Strips, reversible

- Wedge Adapters, for jaws for five-sided machining
- Insertable Plates
- Mounting Screws, for jaws for five-sided machining

Drawing

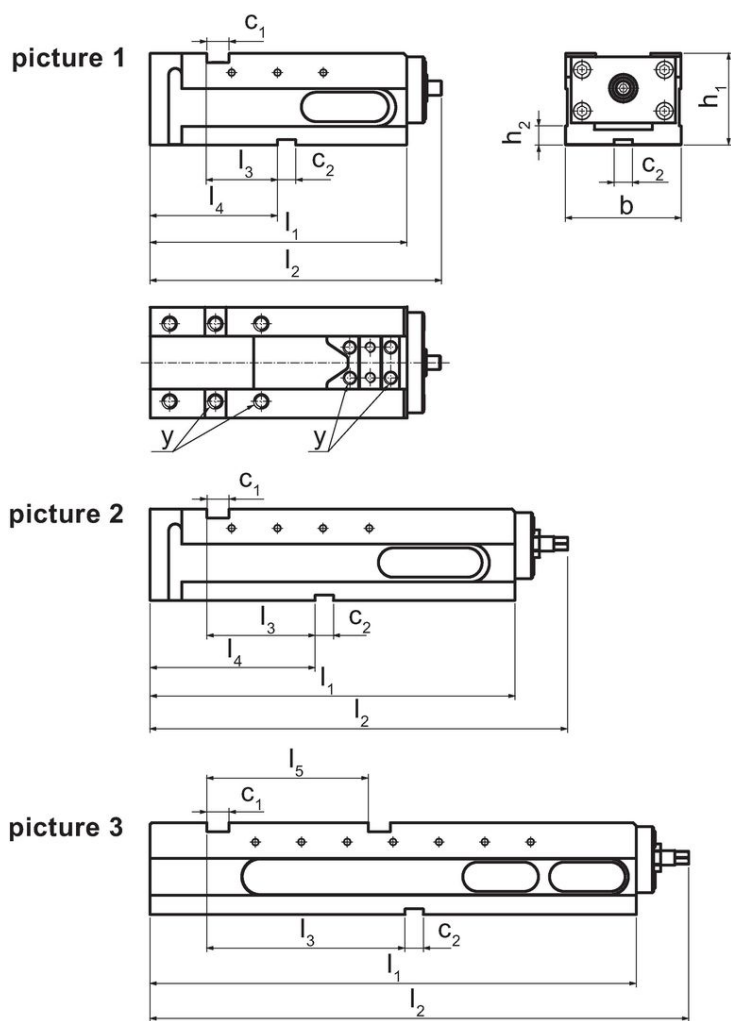

Order information

Jaw width [mm]	Dimensions [mm]											Tightening torque max. [Nm]	Clamping force max. [kN]	Weight [kg]	Art. No.
	b	I ₁	I ₂	I ₃	I ₄	h ₁	h ₂	c ₁	c ₂	y					
MS 125-M – picture 2															
125	126	398	455	118	180	100	21	24	20	M12	30	40	30	1700.200	

Compliance

RoHS compliant

Compliant according to Directive 2011/65/EU and Directive 2015/863.

Does not contain SVHC substances

No SVHC substances with more than 0.1% w/w contained - SVHC list [REACH] as of 23.01.2024.

Does not contain Proposition 65 substances

No Proposition 65 substances included.

<https://www.P65Warnings.ca.gov/>

Free from Conflict Minerals

This product does not contain any substances designated as "conflict minerals" such as tantalum, tin, gold or tungsten from the Democratic Republic of Congo or adjacent countries.