

Combination Clamping Bars

1586.400

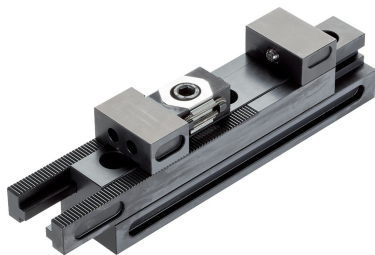

Product Description

The combination clamping bar offers 3 ways to clamp/support the workpiece:

- Floating mode:

Floating mode is used to clamp and support additional clamping points on components. The fixture adapts to the position of the workpiece.

- Centric mode:

The jaws of the clamping bar move in sync. The centre axis of the workpiece remains unchanged even if the outer diameters are modified.

- Machine vice mode:

When this mode is selected, one of the jaws is locked in place on the clamping bar. The second jaw remains movable.

Material

- Tool steel, hardened

Drawing

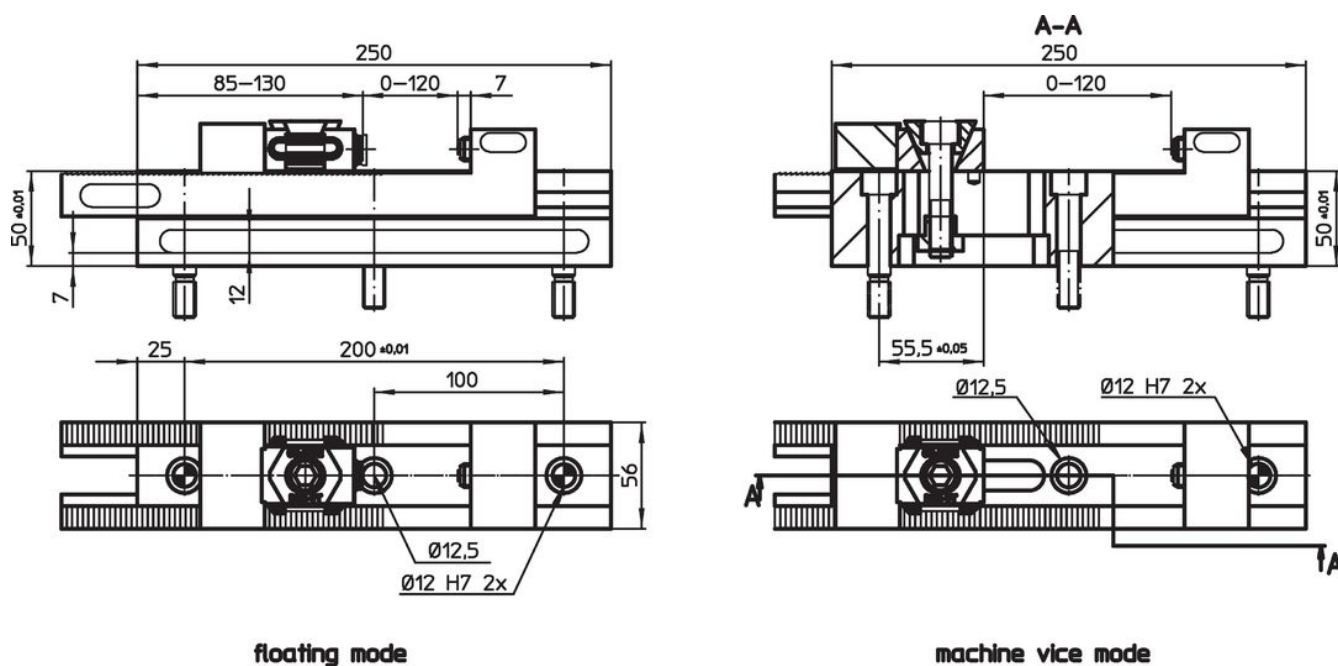



floating mode

machine vice mode

Order information

	Art. No.
 [kg]	
5	1586.400

Accessories

	Number locating screws M12 x 45	Number cap screws M12 x 45	 [g]	Art. No.
fixing screws for clamping bars				
 	2	1	203	1586.401

Compliance

RoHS compliant

Compliant according to Directive 2011/65/EU and Directive 2015/863.

Does not contain SVHC substances

No SVHC substances with more than 0.1% w/w contained - SVHC list [REACH] as of 23.01.2024.

Does not contain Proposition 65 substances

No Proposition 65 substances included.

<https://www.P65Warnings.ca.gov/>

Free from Conflict Minerals

This product does not contain any substances designated as "conflict minerals" such as tantalum, tin, gold or tungsten from the Democratic Republic of Congo or adjacent countries.